

## Designing for Uninterruptible Power: Opportunities for Battery-Based Photovoltaic Systems

By Jim Dunlop

*We asked Jim Dunlop of FSEC's Photovoltaics and Distributed Generation Division to write an article for the Energy Chronicle on using battery-based photovoltaic systems to provide power during outages. The following story describes the typical alternatives for emergency power used during power disruptions and looks at the ways PV systems can meet energy needs.*

Over the past few years, utility power outages have made headline news, and not only caused inconveniences but loss of business, revenue and hardships for many. Whether these outages are caused by hurricanes, ice storms, power shortages or other utility disturbances, our way of life is significantly disrupted without electrical power.



Photovoltaic arrays may serve as temporary, stand-alone power sources in a disaster area.  
(Photo: Robin Flynn)

In the aftermath of major storms and the expected damage to local electrical distribution systems, it is not uncommon for utility power to be out for several days, if not for weeks or even over a month in some cases, and the longer the power remains out, the greater the problems that result. As a solution, many businesses and homeowners are looking into alternative sources of electrical power to mitigate potential — and probable — utility outages.

The high availability and low cost of energy is something Americans have taken for granted for some time, and our entire economy and way of life are predicated on this seemingly inexhaustible supply of energy. While we are accustomed to this panacea, most do not consider the value of energy until supplies become limited or unavailable, like during extended utility outages. In these cases, people are often willing to pay several times what it normally costs to have energy available when we need it.

For example, consider the cost of energy from common alkaline batteries, which we seem to use more and more of over time. A typical “D” cell stores about 4 amp-hours at 1.5 volts, equating to about 0.006 kWh of electrical energy. At a cost of about one dollar apiece, the cost of energy from a “D” cell amounts to about \$167 per kWh — up to 2,000 times what most pay for utility-supplied electricity (\$0.08-0.10/kWh)! So the cost of energy is relative to availability and convenience, and most of us are willing to pay much more for energy when it's not readily available.

Several backup power options are available to businesses and homeowners, with each having limitations on their application as well as operational issues. This article describes three typical back-up power alternatives: uninterruptible power supplies, engine generators and battery-based solar photovoltaic (PV) systems.

## Uninterruptible Power Supplies

Uninterruptible power supplies (UPS) have become increasingly used by homeowners and businesses to back up computers, security systems, office equipment and other critical electrical loads in the event of utility outages or disturbances. UPS systems are available in a variety of sizes ranging from very small units designed to power small loads for short periods of time, to much larger systems designed to power much larger equipment and even entire facilities for extended periods of time.

A typical UPS system includes a battery, charger, inverter and automatic transfer switch, where the battery is used to store electrical energy. While some UPS systems are designed to power critical loads directly from the battery to isolate these loads from the utility service and potential surges at all times, most UPS systems operate in standby mode, while the batteries are kept at full state of charge from utility power. When a utility disturbance occurs, the automatic transfer circuit isolates critical loads from the utility, and connects them directly to the inverter which converts DC power from the battery to AC power at utility service voltages. At this point, there is a limited supply of energy in the battery, which dictates the magnitude and duration of the critical loads that can be operated from these systems.

UPS systems with small batteries may only be able to sustain loads of a few hundred watts like computers for only a few minutes, to allow time to backup work and properly shut down equipment. Larger UPS systems include larger battery banks and inverters capable of sustaining much larger loads for longer periods of time. Ultimately, most UPS systems rely on utility power to recharge the batteries, and without an alternative source to recharge the batteries, these systems are unable to sustain backup of electrical loads for long-term operation.

## Engine Generators

Many homeowners and small businesses are purchasing engine generators as a solution to power outages. Generators are available in a variety of sizes from a few hundred watts to hundreds of kilowatts, and can be portable or permanently installed in service, making them very versatile in meeting a variety of electrical loads in many applications. Prime duty machines are generators designed to operate in continual service, while stand-by machines are designed for backup power applications of limited duration. While generators may be the least initial cost option for back-up power, they can present a number of operational and maintenance issues for users, as well as potential electrical and fire safety hazards if they are not installed and operated properly.

First of all, engine-generators need a fuel source. Smaller portable units are typically fueled by gasoline, while larger and stationary units are typically fueled by diesel, propane (LP gas) or natural gas. During natural disasters, gasoline supplies are often disrupted, there is high demand for product, and many gas stations are closed or operating at reduced capacity due to loss of power or delays in fuel deliveries. Long lines at the few open stations are the norm under these circumstances. To mitigate these supply problems, some opt to store large quantities of gasoline on site in portable containers for stand-by generators, which can be unsafe to transport in vehicles, and hazardous to store in quantities anywhere, particularly interior to buildings. Due to the limited fuel tank size on many small generators and their rate of fuel consumption, users are often required to refuel generators many times a day, which increases the chance for fuel spills, and the risk of fire, personal injury and property damage. All it takes is some gasoline spilled on a hot exhaust manifold and a stray spark or ignition source to ruin someone's life. Permanent generator installations done by professionals often include means to store fuel as well as a means to deliver fuel automatically to the engine, with diesel or propane being the fuel of

"While generators may be the least initial cost option for back-up power, they can present a number of operational and maintenance issues for users ."

choice for these systems. As opposed to gasoline, large quantities of diesel and propane can be stored safely on site in approved containers, and degrade much less over time than gasoline. Diesel fuel is also less flammable than gasoline, and less hazardous when spilled. Incidentally, propane and natural gas can also be used to directly power a number of non-electric appliances, including water and space heating, cooking equipment such as gas ranges, ovens, and outdoor grills, and even refrigerators and freezers. However, some of these appliances may incorporate ignition systems or valves that may require electric power to operate. Clothes dryers and certain air conditioning equipment can also be powered by propane or natural gas, although this equipment also requires electrical power to operate motors and fans.



Due to the limited fuel tank size on many small generators and their rate of fuel consumption, users are often required to refuel generators several times a day.

(Photo: Sherri Shields)

In addition to requiring a readily available fuel source, generators present a number of other operational and safety issues. For one, generators operated in the open can be quite loud, and many can agree this incessant noise is quite bothersome and even unnerving to some in close proximity to the generating equipment. While improved muffler systems and certain generator designs produce less noise, complaints from neighbors are common where large numbers of generators are used after a storm in high density residential areas. Like other internal combustion engines, generators also produce large quantities of deadly carbon monoxide gas in their exhaust. In fact, carbon monoxide poisoning and deaths are quite common in the aftermath of disasters, as folks are operating generators within buildings to prevent theft of the generator or to minimize noise for neighbors, and otherwise

not making proper provisions for ventilation of exhaust gases. Many install generators on porches, adjacent to bedroom windows or entrances that may be opened, increasing the potential for carbon monoxide poisoning.

Generators also require regular maintenance and exercise to ensure that they will operate properly and safely when needed. This required maintenance typically includes oil and filter changes after a number of hours of service or storage period, replacement of spark plugs, and regular inspections of fuel systems for leaks, servicing of starting battery, etc. While smaller units are typically air cooled, larger units are typically water cooled, requiring proper maintenance of antifreeze/coolant levels, and periodic flushing of the entire cooling system. Like any automobile engine, generators must also be routinely exercised to ensure reliable and safe operation. Fouled fuel and carburetors are a common problem for any internal combustion engine that is not routinely and properly operated and maintained. Many automated generator systems incorporate a weekly exercise cycle for 10-15 minutes to ensure they will start and operate when needed. Automatic start generators depend on a starting battery, which when not charged for extended periods will slowly lose capacity to the point where it will no longer start the engine.

Another great concern with portable stand-by generators is they are often not interconnected with building electrical systems in a safe and code compliant manner in accordance with the National Electrical Code. Many utilize extension cords and other non-approved methods for connecting emergency loads, including wiring the generator's output directly to an electrical panel without the appropriate switchgear or overcurrent protection. Many times these cords and connections are undersized for the load intended to be carried, creating a potential circuit overload and fire safety hazard. When generators are connected to an electrical system without the appropriate transfer switchgear, the potential exists for back feeding the utility system and neighbors who may not be expecting their services to be energized. Professional generator installations always include either a manual or automatic transfer switch to ensure that the generator is only connected to loads that have been fully isolated from the utility and other electrical systems.

Like other standby power systems, generators must also be adequately sized for the electrical load they are intended to power. This requires analysis of the building equipment and appliances to estimate the total connected electrical loads, and to ensure that the generator is properly sized and not overloaded. One of the fundamental problems with utilizing generators for backup power is that this sizing often requires the generator to be significantly oversized for the average load, which results in the engine operating at reduced capacity, and at lower than optimal fuel efficiency.

These are just some of the operational and safety issues associated with utilizing engine-generator systems. Those considering the use of generators for standby power are encouraged to consult with the professionals in this business, and to have any permanent generator installations done by licensed electricians.

## Solar Photovoltaic Systems

Solar photovoltaic (PV) systems, or solar electric systems as they are sometimes called, are highly modular electrical power systems that can be designed and configured for a variety of electrical loads and services. PV systems are becoming increasingly used as a supplemental energy supply for residential and commercial facilities throughout the U.S. and abroad. And while their cost is still somewhat higher relative to conventional utility sources in most applications, the performance and reliability of PV systems and equipment have been ever improving. Many states and utilities are providing considerable subsidies to homeowners and businesses that install PV systems, who may also be eligible for other financial incentives including sales and property tax exemptions. In 2006, federal tax credits are available for those who install PV systems on residential and commercial buildings.



Homes equipped with photovoltaic systems can produce their own power. (Photo: Steven C. Spencer)

PV systems have several merits over conventional energy sources. They are fueled by a free source of energy — the sun, and they produce no noise or pollution and require very low maintenance. Certain types of PV systems are designed to provide backup power in the event of utility outages, and have proven quite successful in these applications. However, not all PV systems are designed to provide standby power - only those systems that include battery storage and an inverter and control system designed for that purpose.

To better understand the differences, PV systems are often categorized in terms of the loads they are designed to power, or their connections with other electrical systems. Stand-alone PV systems operate independently of other electrical services and are commonly used for remote power applications, including lighting, water pumping, transportation safety devices, communications, off-grid homes/facilities and many other electrical loads. Interactive PV systems operate in parallel, or interconnected with the utility grid, and supplement utility-supplied energy to a building or facility. Most simple interactive PV systems are not designed to provide backup power, as they are required by electrical codes to disconnect from the grid during outages or disturbances for safety reasons. A third-type of PV system, referred to as a bi-modal or battery-based interactive system, operates normally in interactive mode, but switches emergency loads from the utility to the inverter-battery system during a utility outage, in a manner similar to how most UPS systems operate. The main advantage of a PV system over a UPS system is now we have a means to recharge the battery and power loads for longer periods.

Figure 1 shows a basic diagram of a PV system and the relationship of individual components. The primary component is the PV array, consisting of individual PV modules that are electrically connected and mounted on the ground or rooftop support structure. Array designs can be produced to meet high wind load requirements, with most commercial PV modules constructed with high-strength tempered glass and

certified to withstand nominal impacts from hail, etc. A number of other components are required in any PV system to conduct, control, convert, distribute, and store the energy produced by the PV array. The specific components required depends on the type of system and functional requirements, but typically includes major components such as an inverter to convert DC to AC power, a battery bank, a charge controller, as well as balance of system hardware, including wiring, switchgear and overcurrent protection.

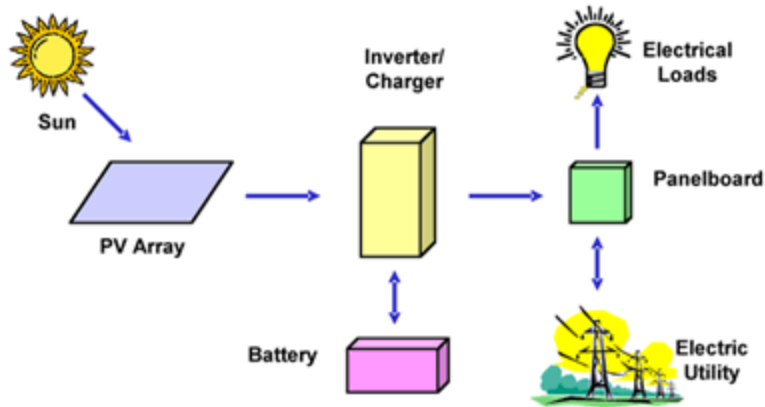

Figure 1. Solar photovoltaic (PV) system and typical components

Stand-alone PV systems are designed to operate independent of the electric utility grid, and are sized to supply specific DC and/or AC electrical loads. These types of systems may be powered by a PV array only, or may use a wind turbine, an engine-generator or utility power as an auxiliary power source in what is called a PV-hybrid system. Stand-alone PV systems can only use the utility as a charging source – they can not send excess energy back to the utility grid. As the energy produced by a PV array varies with the sunlight intensity and is not available at night, batteries are used in most stand-alone PV systems to store energy produced by the array for later use by the electrical loads as needed. Figure 2 shows a diagram of a typical stand-alone PV system powering DC and AC loads. Figure 3 shows how a typical stand-alone PV hybrid system may be configured.

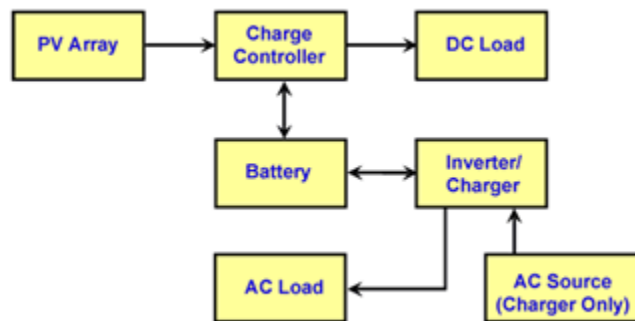

Figure 2. Stand-alone PV system with AC/DC loads.

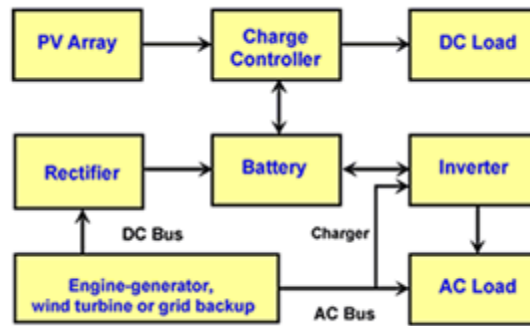

Figure 3. Stand-alone PV-hybrid system.

Grid-connected or utility-interactive PV systems are designed to operate interconnected and in parallel with the electric utility grid. The primary component in grid-connected PV systems is the inverter, which must be listed to UL1741 as an interactive photovoltaic inverter, and clearly labeled as such. In these systems, the DC output of the PV array is directly connected to the inverter, which produces AC power output consistent with the requirements of the utility grid and typical appliances. A bi-directional interface is made between the PV system output and electric utility network, typically at the site distribution panel or electrical service entrance. This allows the AC power produced by the PV system to either supply on-site electrical loads or to back feed the utility grid when the PV system output is greater than the site load demand. At night and during other periods when the electrical loads are greater than the PV system output, the balance of power required by the loads is obtained from the utility.

One important feature of interactive inverters is that they must de-energize if the interactive source of power is lost, and must stop supplying power to the grid when the utility grid is not energized. In other words, these systems are not designed to operate in the event of a utility failure and can not provide power to backup critical loads during utility outages. This safety feature is required for all grid-connected PV systems, and ensures that the PV system will not continue to feed power onto the utility grid when the grid is down, to prevent potential injury to linemen working to restore service. Figure 4 shows a simple diagram of a simple interactive PV system.

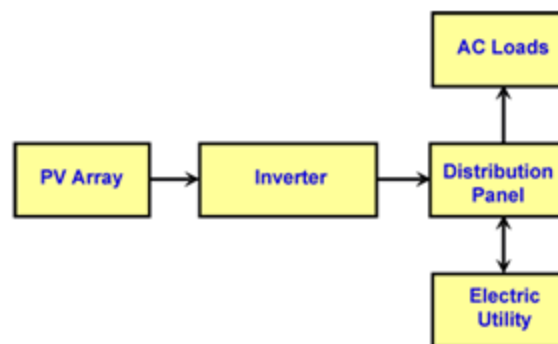

Figure 4. Simple interactive PV system.

## Battery-Based PV Systems for Uninterruptible Power

Bi-modal, or battery-based interactive PV systems, include the benefits of stand-alone as well as interactive PV systems, and are becoming popular for homeowners and small businesses as a backup power supply option for critical loads such as refrigeration, water pumps, lighting and other necessities. Under normal circumstances, these types of PV systems operate in interactive mode and interconnected with the utility, serving the on site loads or sending excess power back onto the grid while keeping the battery fully charged. In the event the grid becomes de-energized, control circuitry in the inverter opens the connection with the utility through an automated bus transfer mechanism, and operates the inverter from the battery to supply power to the critical loads only. In this mode of operation, the critical loads must be supplied from a dedicated subpanel separate from the utility-supplied electrical system, and the total load connected to the subpanel must not exceed the inverter power rating. A bypass circuit is always included to power the critical load subpanel directly from the utility service, and to fully isolate the PV-battery-inverter system for maintenance or service. Figure 5 shows a typical configuration for a battery-based interactive PV system.

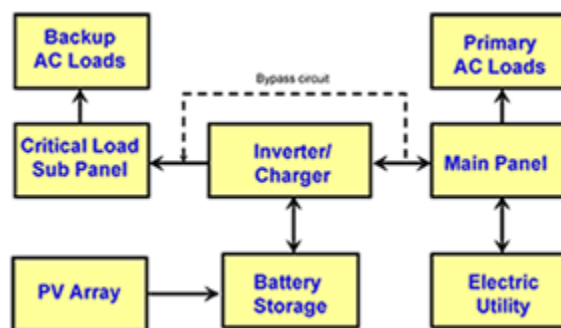

Figure 5. Battery-based interactive PV system

The primary advantage of these systems is the PV array provides a source to recharge the batteries, allowing for extended operation of these systems as compared to simple UPS systems that only provide power for as long as the battery lasts. They also provide supplemental site power during normal utility operations, but their ability to provide backup power is the real advantage over simple interactive PV systems, despite their higher costs (primarily for the battery). The only caveat is that during backup mode, there is only a limited supply of energy available on a daily basis from the PV array to recharge the battery, and the battery has a limited amount of capacity – based on the overall size of the PV and battery systems. Regardless of sizing, careful load management and conservation are essential to ensure the system adequately meets the intended critical loads. Due to the high electrical demand for appliances such as air-conditioners, electric water heaters and electric ranges, these loads are typically not powered from these systems in backup operation, while lower power alternatives such as ventilation fans, solar water heating, and microwaves or gas grills are frequently used instead.

Commercial bi-modal PV inverters are available in sizes from 2-6 kW, and some can be combined in parallel to provide greater overall peak power output. The inverter DC voltage and corresponding battery bank voltage for these systems is typically 24 or 48 VDC. The sizing of these systems depends on a number of factors, but mainly the critical loads that are to be powered in backup operation. Once the peak load and total daily energy have been determined, the PV array must be sized to produce enough energy on an average daily basis to meet that load. The sizing of the battery is somewhat arbitrary, but the amount of storage should be at least equal to the daily load energy requirement.

For example, consider a residential application to backup a refrigerator, lighting, microwave, television,

small fans, and a water pump. Assume the electrical loads and average daily energy consumption is as follows:

Load	Power (watts)	x Time (hours/day)	= Daily Energy (watt-hours)
Refrigerator	300	12 (50% duty cycle)	3600
Lighting	200	4 (evening only)	800
Microwave	1000	0.5	500
Television	200	4	800
Fans	200	8	1600
Water Pump	1000	0.5	500
Total	2900 (2.9 kW)		7800 (approx. 8 kWh/day)

Based on this 2.9 kW peak load, a 4 kW bi-modal PV inverter would be adequate for this application, and would support some future addition of load as required. The PV must be able to produce 8 kWh per day, and the sizing will be based on average sunlight conditions in the given area. In Florida for example, a nameplate 1 kW PV system is capable of producing at least 3.5 kWh, so for this application a PV array size of approximately  $8/3.5 = 2.3$  kW would be required, which would take some 200 square feet of surface area. For one day of battery storage equivalent to the daily load, 8 kWh of battery would be required, which can be supplied by approximately 12 typical flooded lead-acid golf cart batteries – which incidentally are a good deep-cycle battery for this application. Another popular option is the more expensive valve-regulated or sealed lead-acid battery, which do not require the maintenance and water additions like flooded types, and are suited for indoor applications.

## Summary

Battery-based interactive PV systems present an alternative to generators and simple UPS systems for emergency backup power. Like any other electrical equipment, PV systems should be designed and installed in accordance with the National Electrical Code, as well as meeting other applicable building code requirements. In general, it is highly advisable to have qualified, licensed contractors install PV systems. In addition to the local electrical permitting and inspection process, interconnection agreements must also be completed with the local utility for any interactive system. Most utility companies offer a simple interconnection agreement for small PV systems, which may include special requirements for inspections, disconnects, metering and insurance.

Following are major U.S. manufacturers of bi-modal interactive battery-based PV inverters:

Xantrex: <http://www.xantrex.com>

Outback Power: <http://www.outbackpower.com>

Beacon Power: <http://www.beaconpower.com>

Alpha Technologies: <http://www.alphatechnologies.com>

These companies have authorized distributors for their products, and those distributors often recognize dealers and contractors who sell and install their products and systems locally. Those interested in pursuing PV systems for either supplemental energy production or back-up power are encouraged to contact their local supplier or contractor. In Florida, the Florida Solar Energy Industries Association (FLASEIA) maintains a list of certified Florida solar contractors: <http://www.flaseia.org>. Nationally, the North American Board of Certified Energy Practitioners (NABCEP) maintains a list of PV installers having passed a national exam and meeting certain other eligibility requirements: <http://www.nabcep.org>.

For additional information on PV systems technology, visit the following Web sites:

Florida Solar Energy Center: <http://www.fsec.ucf.edu/pvt/>

Solar Energy Industries Association - <http://www.seia.org/>

U.S. Department of Energy Solar Energy Technologies Program: <http://www.eere.doe.gov/solar/>

Sandia National Laboratories PV Program: <http://www.sandia.gov/pv>

National Center for Photovoltaics/National Renewable Energy Laboratory: <http://www.nrel.gov/ncpv/>

The Source for Renewable Energy - <http://www.sourceguides.com/energy/>

World Directory of Renewable Energy Suppliers and Services -  
<http://www.jxj.com/suppands/renenerg/index.html>

Home Power Magazine: <http://www.homepower.com>